



TECHNICAL SPECIFICATION

AST-C0097A

Adapter eblow N male / N Female

A0-12/07/07

1. DIMENSIONS (mm)

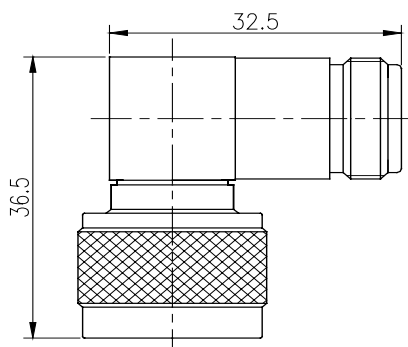

2. ELECTRICAL CHARACTERISTICS

Impedance		: $50 \Omega \pm 2\%$
Operating frequency range		: $DC-3GHz$
Insulation resistance		: $\geq 5000M \Omega$
Contact resistance	Inner conductor	: $\leq 1m \Omega$
	Outer conductor	: $\leq 0.25m \Omega$
Voltage test (at sea level)		: $2.5kv \text{ eff}/50Hz$
Operating Voltage(at sea level)		: $1.5kv \text{ eff}/50Hz$
Reflexion coefficient		: ≤ 1.10
Screening effectiveness		: $\geq 115dB$

3. MECHANICAL CHARACTERISTICS

Coupling standard	: <i>Compliance with IEC169-16 standard</i>
Body	: <i>Copper alloy-plated brass</i>
Insulator	: <i>PTFE</i>
Inner conductor	: <i>Silver plated bronze</i>
Coupling waterproofing	: <i>Silicone O-ring</i>
Coupling torque	: $2.5N.m$
Operating temperature range	: $-40^\circ C < \theta < +85^\circ C$
Weight	: $75.3 g$